

TWUHF3100-0022

Twinax UHF Plug Solder For RG22

75Ω

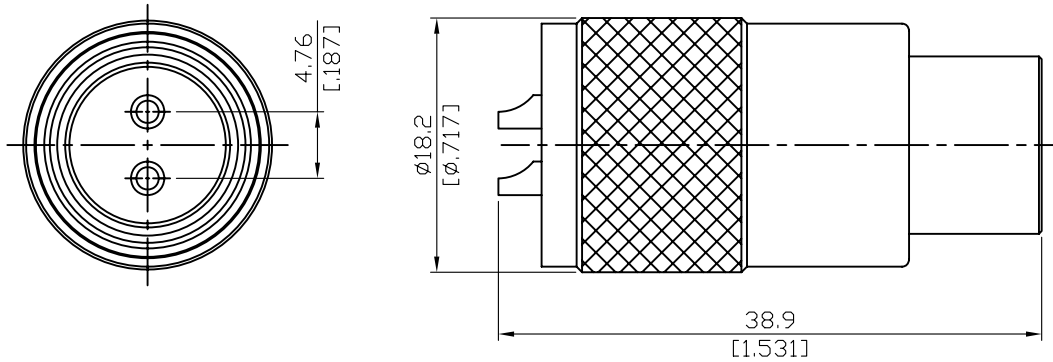

Parts	Material	Plating (Micro-inch)
Contact Pin	Brass	Gold 4 Over Nickel-Phosphorus Alloy 80 Over Copper 20
Insulator	Teflon	
Body	Brass	Tin-Zinc-Copper-Alloy 100 Over Copper 50
Coupling Nut	Brass	Tin-Zinc-Copper-Alloy 100 Over Copper 50

This part number complies with RoHS.

Notice: JYEBAO reserves the right to make modifications demand appropriate.

JYE BAO CO., LTD.

CABLE ASSEMBLY INSTRUCTION

TWUHF3100-0022	DATE	2017/09/25	REV	—
----------------	------	------------	-----	---

<p>A</p>  <p style="text-align: center;">BODY</p>	<p>B</p>  <p style="text-align: center;">SHELL</p>
--	--

DIAGRAM	ASSEMBLY INSTRUCTION
---------	----------------------

	<p>Step 1: STRIP AS SHOWN.</p>
--	--------------------------------

	<p>Step 2: SLIDE SHELL " B " OVER CABLE.</p>
---	--

	<p>Step 3: PUT PREPARED CABLE INTO CONNECTOR " A " AND SOLDER IN " X " AND " Y ".</p>
---	---

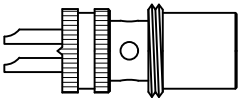
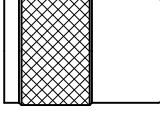
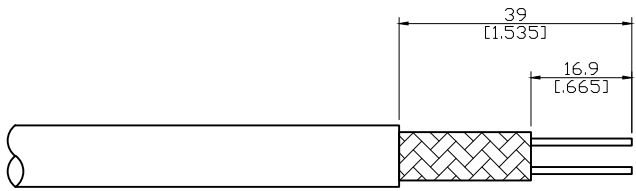
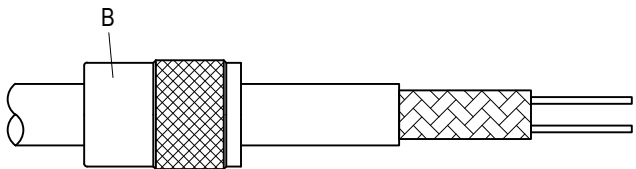
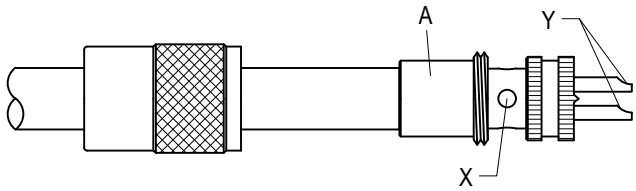
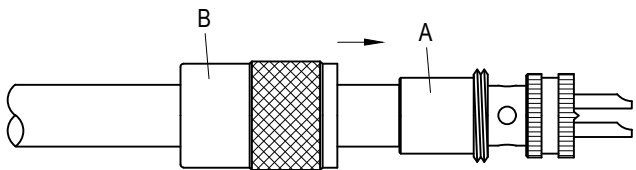
	<p>Step 4: FINALLY SCREW SHELL " B " ON CONNECTOR " A ".</p>
---	--

This part number complies with RoHS.

Notice: JYEBAO reserves the right to make modifications deemed appropriate.

APPROVED	CHECKED	DRAWING
----------	---------	---------

Albert