

# Data Sheet



## ACS 2004 N / Art. Nr.: 5055



### 4x Antenna Switch with sequential preamplifier/final amplifier-control

The antenna control system ACS 2004 allows the activation of four different antennas for all amateur bands from 80 m to 70 cm over a single feeder cable. It consists of the control unit AC 2004 and the water protected outdoor unit AS 2004. Both devices communicate over a single feeder cable, which additionally allows four independent amplifiers for each antenna connection to be switched on or off independently. For the first time a complete, sequential preamplifier control is built into such a system, that, at the same time, controls also power amplifiers processes. Preamplifiers and power amplifiers can be controlled by a PTT, balanced to ground or to + 5...12V.

### Standard connection:

According to the included installation plan up to four antennas can be connected to the input sockets of the antenna switch, which is mounted at the mast.

If desired, preamplifiers are inserted in the common way between the according antenna and the antenna switch. Via the feeding cable now the AS 2004 and the internal control unit AC 2004 are connected. The socket TRX (PA) has to be connected to a transceiver, receiver or power amplifier.

After applying the operation voltage the system is operational already. If our preamplifier is used, no wiring of the PTT control inputs is necessary, if, for example, a transceiver is used that does not exceed the acceptable load of the HF-Vox in the preamplifier. For the use of separate power amplifiers with higher power, a further PTT connection from the transceiver to the AC 2004 and from it to the PTT input of the power amplifier has to be provided.

If existent, a HF-Vox control in the power amplifier has to be deactivated implicitly! The use of the PTT-control offers a further

# Data Sheet



## ACS 2004 N / Art. Nr.: 5055

---

advantage: For the protection of the switch contacts in the HF-Relays and the preamplifiers in use, switching to a different antenna connection is prevented, as long the PTT switch of the transceiver is activated!

### Extended connection:

Herewith the HF-output of the Controller can be allocated via external relays to various transceivers or final amplifiers. Then the selection of the units that should be activated is controlled automatically by the keys of the Controller. Please refer to the corresponding wiring scheme. You should make sure that the used relays not only are able to transfer the power of the amplifier without problems. It is recommendable to control the cross-talk attenuation of the relays, as else the other transceivers may be damaged easily! At the PTT switching output point 7 of the Controller an Open-Collector transistor is available, which can direct a maximum current of 500 mA to ground. The same switching capacity is offered by the output points 5 and 6, to switch relays.

### Operation of the switching system:

After switching on the operating voltage, a short test of the electrical connection to the remote antenna switch is carried out. When wiring is recognized as ok, the unit is switched on using factory default settings: Antenna 1 is selected without activated power feed for preamplifiers. In case of a disruption between indoor and outdoor unit the LED for the preamplifier and the LED of the chosen antenna connection will blink alternatively in slow speed. In case of a short they will blink quickly.

### Operating error possible!!

**If a voltage for a preamplifier is switched to an antenna connection which does not have a preamplifier, but additionally serves an antenna with grounded inner conductor, a short will happen that cannot be indicated!!**

**Due to the internal overload protection this voltage will be switched off, but activated by the PTT each time it is switched. That will cause a short-time maximum current. So please keep the external wiring of the AS 2004 in mind.**

In the delivery status the antenna socket 1 is activated without remote feeding. All parameters changed hereafter will be kept stored even without operating voltage.

### Choice of antennena connection:

The connection is activated by pressing the key 1 – 4, which is indicated by the corresponding LED. Key 1 controls the antenna socket 1, and so on, up to No. 4..

# Data Sheet



## ACS 2004 N / Art. Nr.: 5055

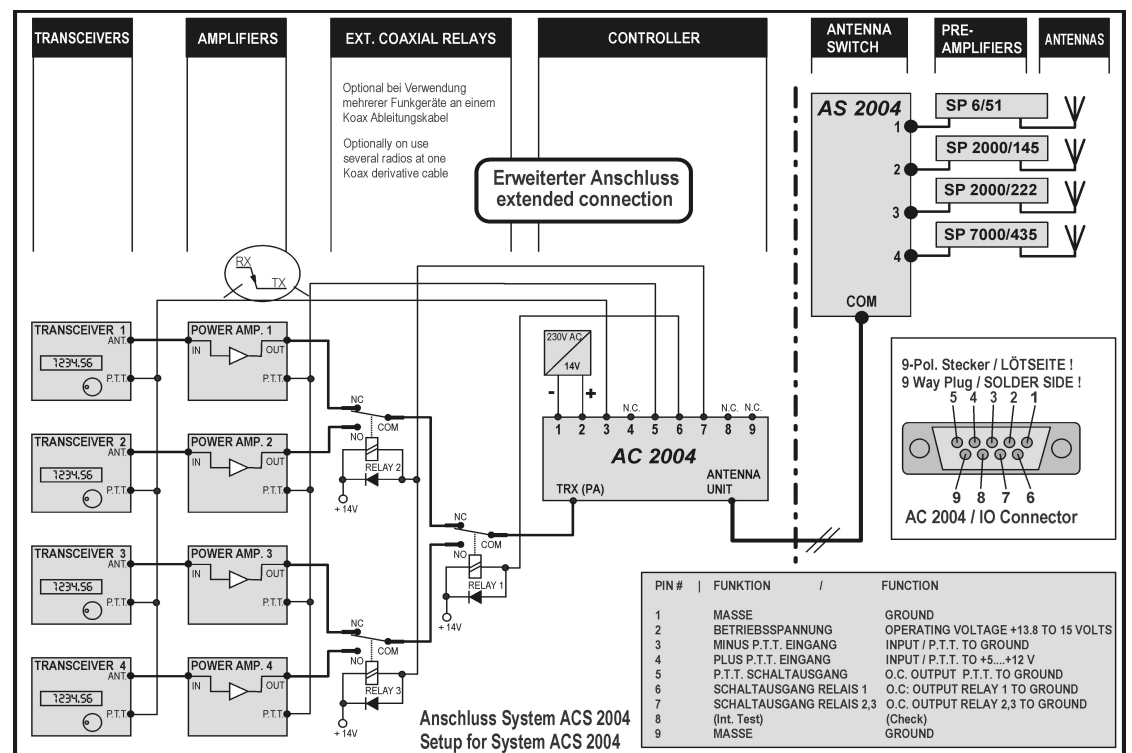
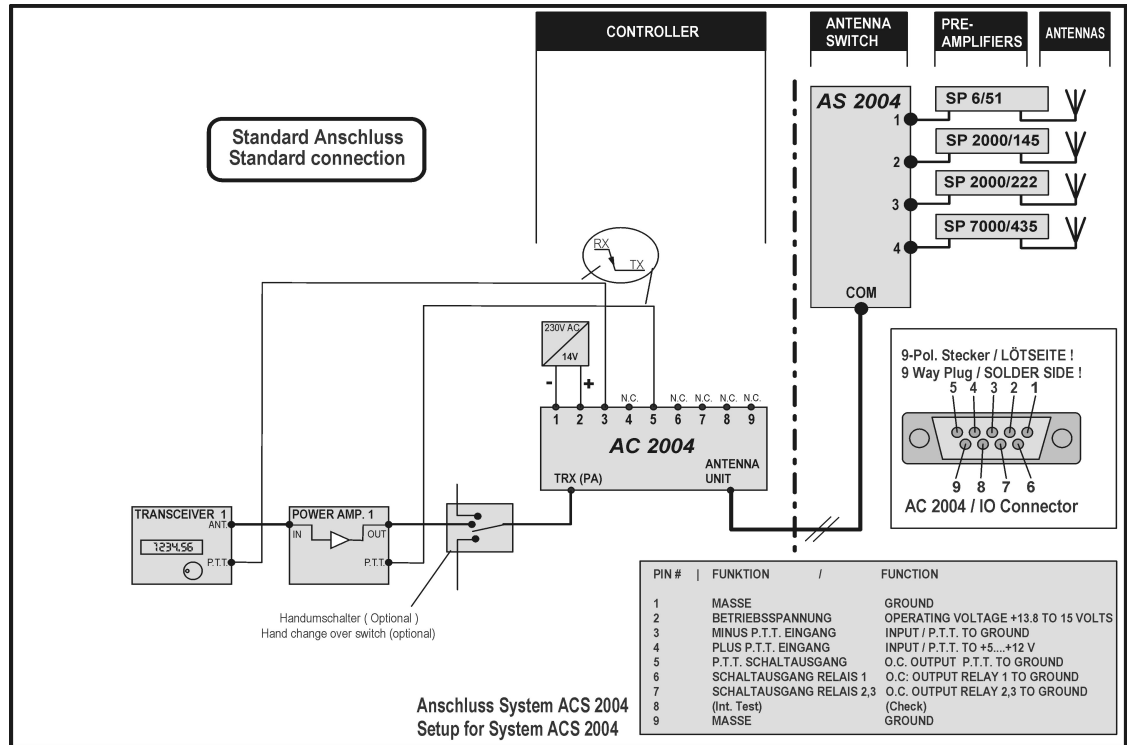

# Data Sheet



## ACS 2004 N / Art. Nr.: 5055

---

### Choice of an Antenna Amplifier:

For switching on or off the operating voltage for a preamplifier, the key of the corresponding antenna connection has to be pressed a bit longer - ca. 2..3 seconds. Hence it is prevented that, by accident, voltage is given to an antenna connection without preamplifier. The preamplifier-LED is always valid for the antenna connection activated at a time. While selecting the keys it is visible immediately, at which connection a (inserted) preamplifier is fed with voltage.

Do not open the unit. It does not contain any parts needing maintenance. If you need help regarding technical matters, please contact our team::

[technik@ssb-electronic.de](mailto:technik@ssb-electronic.de)

### Technical Data

Frequency range	80m to 70cm, all Amateur bands
Capacity (PEP)	80m..10m/1.5KW PEP 6m/2m each 800 W PEP 70cm/600W PEP
Insertion loss	80m - 10m < 0.1 dB 6m/0.15 dB, 2m/0.25 dB 70cm/0.3 dB
Antenna inputs	4
Preamplifier voltage	0.5A max. load
PTT-switching output for final amps (Point 5)	0.5A/30V max., Open Collector
Relay-switching outputs (Points 6+7)	each 0.5A/30V max., Open Collector
- PTT Input (Point 3)	< 2V
+ PTT Input (Point 4)	> 5V
Operating voltage	12..15 Volt, recommended: 13.8V..14.5V
Connection norm	N – Socket
Mast diameter (AS 2004)	58mm max.

# Data Sheet



## ACS 2004 N / Art. Nr.: 5055

### Disposal of your old appliance



This product is covered by the European Community directive 2002/96/EC. 2. All electrical and electronic products should be disposed of separately from the municipal waste stream via designated collection facilities appointed by the government or by the local authorities. The correct disposal of your old appliance will help prevent potential negative consequences for the environment and the human health. For more detailed information about the disposal of your old appliance, please consult your city office, waste disposal service or the shop where you purchased the product. Within Germany, the above regulations are also valid for the disposal of batteries and accumulators accordingly.

### Declaration of Conformity



Herewith we declare that this product complies with all relevant regulations for the product within the guidelines 73/23/EWG, 89/336/EWG and 99/5/EG of the Council:

**EN 301 489-15** Electromagnetic compatibility and Radio Spectrum Matters (ERM) Electromagnetic Compatibility (EMC) standard for radio equipment and services. Part 15: specific conditions for commercially available amateur radio equipment.

**EN 301 783-1** Electromagnetic compatibility and Radio Spectrum Matters (ERM); Land Mobile Service; commercially available amateur radio equipment. Part 1: technical characteristics and methods of measurement.

**EN 301 783-2** Electromagnetic compatibility and amateur radio equipment. Part 2: harmonized EN covering essential requirements under article 3.2 of the R&TTE Directive.

**EN 60950-1:2001** Information technology equipment – safety. Part 1: General requirements.

#### Manufacturer:

SSB-Electronic GmbH  
Am Pulverhäuschen 4  
59557 Lippstadt

#### Contact:

E-Mail : [technik@ssb-electronic.de](mailto:technik@ssb-electronic.de)  
Telephone : +49(0)2941 – 93385 - 0